

Native outdoor Energy Storage System

SUNSYS HES L from 100 kVA / 186 kWh to several MVA / MWh systems

2022



SUNSYS HES L[©]

Native outdoor Energy Storage System

from 100 kVA / 186 kWh to several MVA / MWh systems

SUNSYS HES L



The solution for

- > Commercial and industrial buildings
- > EV charging infrastructure
- > Isolated microgrids
- > Resilient microgrids
- > Renewable energy integration

Main advantages

- > High safety
- > Extreme flexibility
- > Fast and error-free installation
- > Easy maintenance
- > Maximum savings and fast ROI

Conformity to standards

- > **Safety:** IEC 62368-1; IEC 62933-5-2; UL 9540A
- > **EMC:** EN 61000-6-2/4
- > **Mechanical:** EN 60529; EN 62262
- > **Environment:** RoHS; REACH; IEC 61249-2-21; RAAE 2012/19/UE
- > **Communication protocol:** Modbus TCP
- > **Grid code:** Europe: EN 50549-2 & EN 50549-1; Germany: VDE AR-N 4110; VDE AR-N 4105; Italy: CEI 0-16; UK: G99/1; France: VDE 0126-1-1; Belgium: C10-11

For more information, please contact us.

Expert Services

An experienced and skilled team is at your service to make your project a success!

- > **Project development:** pre-sales support, project design & realisation
- > **Deployment & integration:** training, field inspection, pre-commissioning, commissioning
- > **Operation:** maintenance contracts, spare parts replacement, remote monitoring
- > **Warranty extensions:** both on the C-Cab and B-Cab

For more information, please contact us.

SUNSYS HES L is a native outdoor system that merges proven technologies to create an all-in-one solution that is greater than the sum of its parts. Partnering with CATL, Socomec has selected the EnerOne liquid cooled LFP battery system as the optimum battery for SUNSYS Hybrid Energy Storage.

When it comes to safety, this system sets a new standard.

The range is available in a variety of sizes and can work both as grid follower and grid-former.

High safety

The safest system ever, combining two proven technologies to deliver a winning formula.

CATL EnerOne Liquid-Cooled Battery: the SUNSYS B-Cab L utilises the stable chemistry of Lithium Iron Phosphate (LFP) batteries that can withstand thermal runaway.

Socomec Power Conversion System (PCS): the SUNSYS C-Cab L uses safe conversion technology to limit the common mode noise effect.

SUNSYS HES L is compliant with UL9540-2020: the safety standard associated with complete Energy Storage Systems and Equipment.

Extreme flexibility

The SUNSYS HES L system is based on 3 standard cabinets - C-Cab, B-Cab and DC-Cab – and 1 “engineered to order” AC-Cab that can be adapted on a case-by-case basis to be as close as possible to your installation requirements.

In addition, the installation can be upgraded with:

- **increased power** with the addition of one or more 50 kVA power modules in the C-Cab, or even additional C-Cabs,
- **increased energy** with the addition of B-Cabs .

Fast and error-free installation

All Battery cabinets are shipped fully assembled - with internal modules mounted - for maximum quality with the minimum transportation costs and installation time.

Also, for an error-free installation:

- **drilling plates are provided** to prepare the drilling locations,
- **the intelligence (PMS & BMS) is integrated** inside the C-Cab to reduce complexity, and **DC connecting kits** are available to simplify the connection between the converters and batteries.

Easy maintenance

Reduced maintenance with HVAC replaced by air filters, the system can be maintained by the customer with ease.

Seamless service during maintenance as one C-Cab L module can be changed without interruption whilst keeping the others operational.

Furthermore, one battery rack can be disconnected for module replacement keeping the others operational.

Suitable for all of the following applications

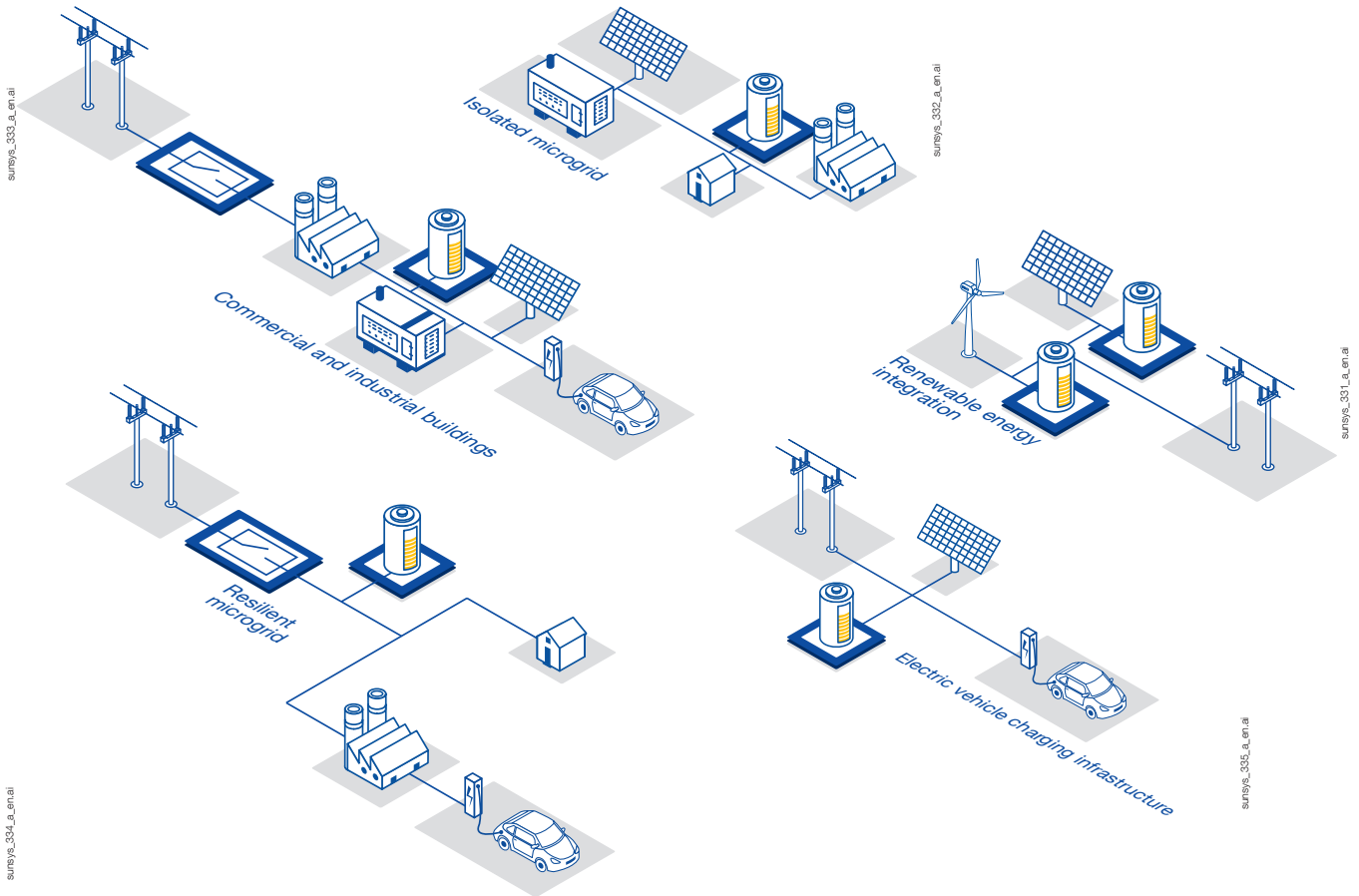

4 stackable units for maximum flexibility



C-Cab

- Bidirectional power converter
- 100 to 300 kVA / cabinet
- Automation functions
- AC/DC distribution and protection
- Battery management system
- IoT Ready

B-Cab

- Lithium ion battery
- LFP technology
- 186 kWh / rack
- Liquid cooling thermal management
- Integrated fire safety detection and extinction system

DC-Cab

- DC distribution panel
- Required for configurations with 7 to 9 B-Cabs per C-Cab
- Battery protection
- Battery auxiliaries power supply

AC-Cab

- AC power distribution cabinet
- Multi-source paralleling
- Islanding function
- Synchronisation after mains return
- Short interruption transition

SUNSYS HES L[®]

Native outdoor Energy Storage System

from 100 kVA / 186 kWh to several MVA / MWh systems

Many system configurations are available to meet customer requirements

Energy (kWh)	1 rack	2 racks	3 racks	4 racks	5 racks	6 racks	7 racks	8 racks	9 racks
Power (kVA)	186	372	558	744	930	1116	1302	1488	1674
100									
150									
200									
250									
300									
350									
400									
450									
500									
550									
600									
650									
700									
750									
800									
850									

Standard configurations without DC -Cab. Standard configurations with DC -Cab.

Maximum savings and fast ROI

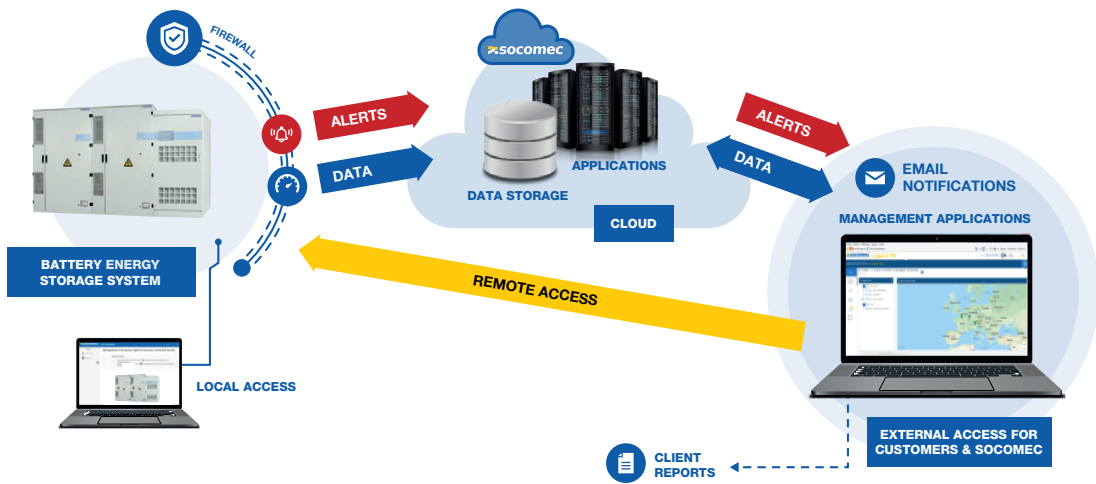

Local management

We have developed a modular and adaptive platform - our Power Management System (PMS) being the brain of the system.

This open platform, integrated in the C-Cab, provides access to:

- peak shaving, energy shifting, self-consumption and fuel saving to maximise valuable savings,
- transition from on-grid to off-grid mode via the black start function,
- multi-source microgrid autonomous management and the potential for additional customisation,
- compatibility with third-party supervision systems (EMS, SCADA) for additional functionality.

Remote monitoring

In addition, the C-Cab also integrates IoT devices that make it possible to continuously monitor the system remotely.

These devices enable the following:

- web dashboard for on-line monitoring,
- web access to the system KPIs,
- smartphone app,
- maintenance information: scheduled visits and remote firmware upgrade.

Technical Data

System information	
Power modularity	50 kVA power modules - up to 300 kVA per cabinet
Symmetrical overload	110% during 30 min - 125% during 10 min - 150% during 30 s
Chemistry	LFP - Lithium Iron Phosphate
Energy Nameplate	186 kWh per cabinet
AC/AC Max Round Trip Efficiency	90%
Maximum C-rate	0.5 C
Maximum current	83 A charging / 87 A discharging per 50 kVA power module
AC connections	3*240 mm ² (consult us for higher section)
Rated voltage (Un)	400 Vac (3ph+N) -20%/+10%
Rated frequency	50 Hz ±6%
Fire protection	Fire Safety System including smoke detectors, heat detectors and aerosol
Environment	
Environment installation	Native outdoor
Degree of protection	IP 55
Operation temperature	-20 to +45 C° without derating
Storage temperature	-20 to +60 C°
Relative humidity	4 to 95% w/o condensation (internal cabinet heating)
Acoustic level at 1 m	< 70 dB
Maximum altitude	1000 m without derating (consult us for requirements above this)

Two system installation options according to the space available on your site

On-line installation

Up to 6 B-Cabs - dimensions (mm)

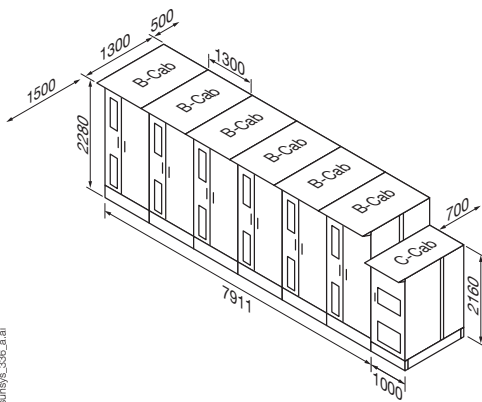

Back-to-back installation

Up to 6 B-Cabs - dimensions (mm)

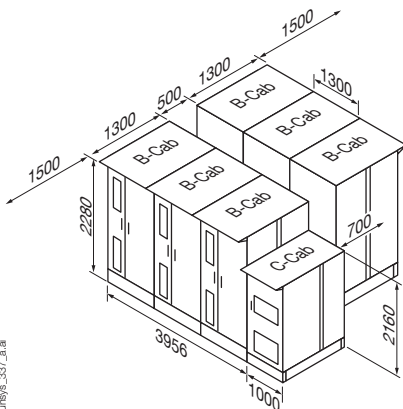

From 7 to 9 B-Cabs - dimensions (mm)

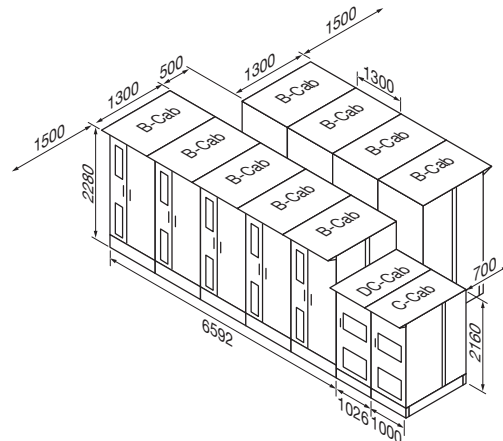



Dedicated engineering and project management team for energy storage solutions

Our expertise:
a wide range of skills

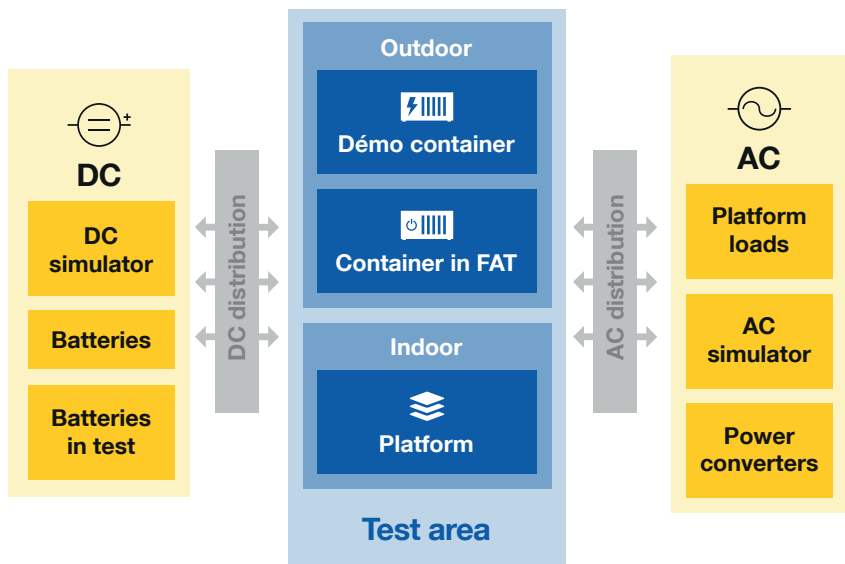

Socomec testing platform

- Electrical
- Mechanical
- Thermal
- Automation
- Battery technology
- Communication & IOT

Working together to co-design your project

You have a project, requirements and objectives.

We have a team, skills and a depth of experience.

Together, we will succeed with your project.



Our workforce: a complementary set of profiles

- **Electro-mechanical engineers** to design cutting-edge energy storage architectures.
- **Automation engineers** to develop energy storage control systems.
- **Battery experts** to provide advanced analysis for energy storage solutions.
- **Dedicated customer resources** to manage the project from design to commissioning.
- **Service experts** to carry out the commissioning and to support customers for operation.



Our means: high investment to provide qualified solutions

- **Demonstrators** to design and test new services in real operating conditions.
- **Socomec testing platform** to lead factory acceptance tests of the complete customers storage solution (capability to test up to 4 containers in parallel):
 - Two independents 400kW power grid.
 - Islanding possibility.
 - AC and DC simulators to generate grid events and batteries.
 - Multiple loads to simulate customer facilities.
- **External tools:** Socomec has developed partnerships with several external laboratories or grid operators to carry out additional tests.

Contact us to visit our test and qualification facilities.



Your benefits

- **Custom design:** solution adjusted as closely as possible to your demand.
- **Optimised cost:** all skills and tools are mastered internally.
- **High quality:** industrial tool and process ISO 9001 certified.
- **Reliability and availability:** thanks to proof load test and remote support.

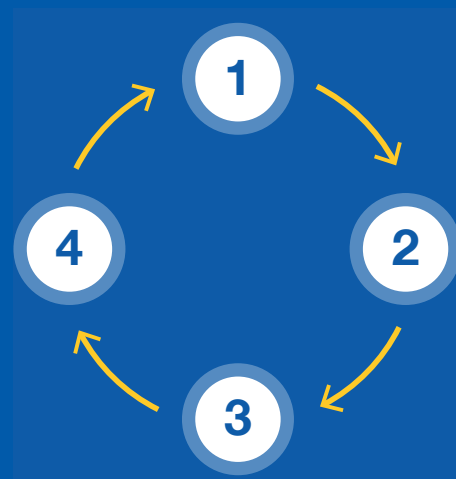

A proven process to support customer's projects

Based on our experience and battery energy storage achievements, Socomec has designed a process to support customer projects

- 1 Pre sales support**
 - Analysis of customer requirements.
 - Pre-technical design.
 - Quotation of the technical solution.
- 2 Project design and realization**
 - Allocation of a project manager to lead the project.
 - Design of the complete solution by co-engineering with the customer.
 - Production and procurement of all equipment.
- 3 Tests and commissioning**
 - Factory acceptance tests.
 - Site inspection.
 - Site acceptance tests and commissioning.
 - Documentation and customer training.
- 4 Operating and maintenance services**
 - Troubleshooting, data management and reporting.
 - Periodic on-site inspections and preventive maintenance.
 - Warranty management.

Socomec: our innovations supporting your energy performance

1 independent manufacturer

3,600 employees
worldwide

10 % of sales revenue
dedicated to R&D

400 experts
dedicated to service provision

Your power management expert



POWER
SWITCHING



POWER
MONITORING



POWER
CONVERSION



ENERGY
STORAGE



EXPERT
SERVICES

The specialist for critical applications

- Control, command of LV facilities
- Safety of persons and assets
- Measurement of electrical parameters
- Energy management
- Energy quality
- Energy availability
- Energy storage
- Prevention and repairs
- Measurement and analysis
- Optimisation
- Consultancy, commissioning and training

A worldwide presence

12 production sites

- France (x3)
- Italy (x2)
- Tunisia
- India
- China (x2)
- USA (x3)

28 subsidiaries and commercial locations

- Algeria • Australia • Belgium • China • Canada
- Dubai (United Arab Emirates) • France • Germany
- India • Indonesia • Italy • Ivory Coast • Netherlands
- Poland • Portugal • Romania • Serbia • Singapore
- Slovenia • South Africa • Spain • Switzerland
- Thailand • Tunisia • Turkey • UK • USA

80 countries

where our brand is distributed

HEAD OFFICE

SOCOMECC GROUP

SAS SOCOMECC capital 10 646 360 €
R.C.S. Strasbourg B 548 500 149
B.P. 60010 - 1, rue de Westhouse
F-67235 Benfeld Cedex
Tel. +33 3 88 57 41 41 - Fax +33 3 88 57 78 78
info.scp.isd@socomecc.com

YOUR DISTRIBUTOR / PARTNER

www.socomecc.com



100 years
OF SHARED ENERGY
1922 — 2022

socomecc
Innovative Power Solutions