

PROGRAMMABLE RELAY I/O CARD USER MANUAL

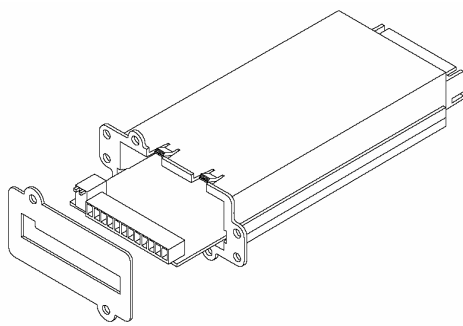

PRESENTATION FEATURES

This relay I/O card is an UPS management product with 6 relay output contacts for monitoring the status and 1 input contact as a shutdown UPS or a battery test command.

Features:

- Monitor UPS events.
- 6 programmable relay output contacts.
- Configurable normal open or normal close for each relay contact.
- Configurable UPS shutdown delay time.
- Configurable input signal as shutdown UPS or battery test.
- Has the ability to protect up to 6 computers unattended shutdown gracefully.

TECHNICAL SPECIFICATION

TECHNICAL SPECIFICATION

Size	130 x 60 mm
Weight	200 g
Operating Temperature	0 ~ 40° C
Operating Humidity	10 ~ 80 %
Power Input	8 ~ 20V DC
Power Consumption	1.2 Watts

OUTPUT CONTACT RATING

Relay	Maximum	
	DC Voltage	DC Current
R1~R6	24 V	1A

INPUT RATING

Input	Maximum	
	DC Voltage	DC Current
Input	24 V	10 mA

APPLICATION EXAMPLE

In this case we'll use the default settings, please set SW1 and SW2 to the OFF position. Apply 12VDC to **Common** contact and connect the lamps to **R1~R6** terminals. Install a push button from the Common contact to the input terminal. Press the button for at least 3 seconds to shutdown the UPS remotely.

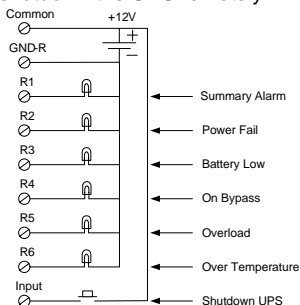

INTERNAL CIRCUIT

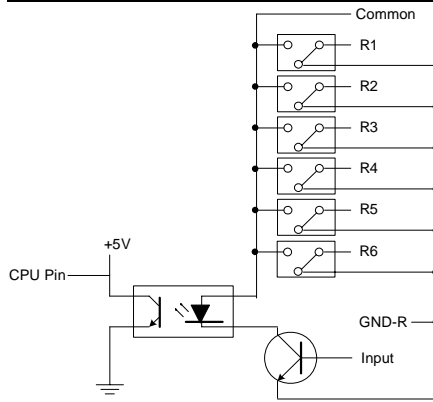

OUTLINE

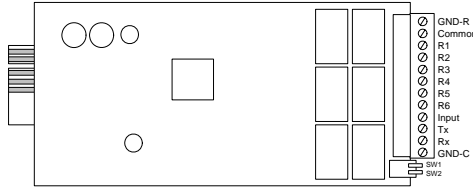

I/O PINOUT

GND-R: Ground for relays		
Common: 12~24VDC		
Default Alarm Event		
R1	Summary Alarm	
R2	Power Fail	
R3	Battery Low	
R4	On Bypass	
R5	Overload	
R6	Over Temperature	
Input: Remote shutdown or battery test		
Tx:	Transmit to PC, connect to sub9-pin2	
Rx:	Receive from PC, connect to sub9-pin3	
GND-C: Ground for configuration Tx and Rx pins		
	OFF (Default)	ON
SW1	Normal open for default settings	Normal close for default settings
SW2	Default settings	Customized settings

PROGRAMMABLE CONTACTS

COMMUNICATION SETUP

1. Connect **Tx** to pin2, **Rx** to pin3 and **GND-C** to pin5 of PC RS232 port.
2. In the Windows environment, launch the Hyper-Terminal program then open the specified COM port.
3. Set the following properties:
Baud rate: **2400**, Data Bits: **8**, Parity: **None**
Stop Bit: **1**, Flow Control: **None**

CONFIGURATION

1. Press <Enter> to get the main menu of the programmable relay card.

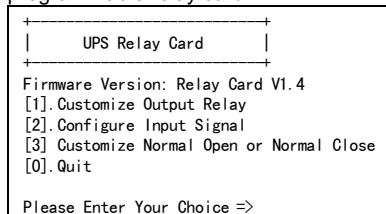

2. Press '1' to configure the alarm event for **R1~R6**.

Contacts **R1~R6** can be configured for different power events.

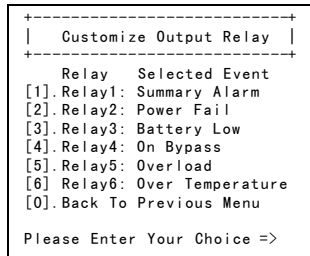

Once the configuration is complete **SW2** MUST be switched to the ON position to apply the new settings, switch **SW2** back to the OFF position to reset to the default settings.

3. Press '2' to configure the **Input** signal.

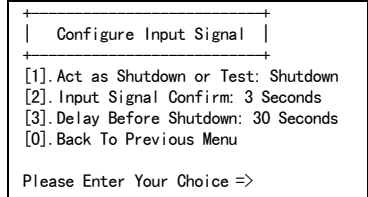

In this menu, the input signal can be redefined as shutdown UPS or battery test signal. Meanwhile, the UPS shutdown delay time is also adjustable to a maximum of 9999 seconds.

4. Press '3' to configure the normal open or normal close for each relay.

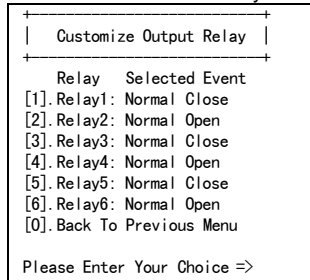

Once the configuration is complete **SW2** MUST be switched to the ON position to apply the new settings. Switch **SW2** back to the OFF position to reset to the default settings.

5. Press '0' to quit this configuration session. The system would prompt you to save or not. Press 'Y' to save your settings, 'N' to ignore.

POWER OPTION IN WIN 2000/XP

This relay card has the ability to provide UPS signals for Windows NT4/2000/XP/2003. First connect the RS232 port on the PC to the relay card as shown:

Then open the power option from control panel and click on the UPS tab to setup the signals polarity, select **Positive** for Power Fail, Low

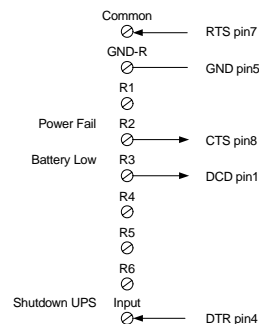

Battery and UPS Shutdown. Since the **R1~R6** contacts are programmable, the output contacts can be configured for 3 computers with 2 signals (power fail and low battery) or 6 computers with one signal (power fail or low battery).

Note: All of the computers must have the same earth ground potential. Connect all of the computers input power to the same UPS.